

Dawson Mineral

5 COLOURS / 15 SIZES / 2 FINISHES / VARIOUS SPECIAL PIECES

An authentic and modern stone effect across both indoor and outdoor products, Dawson Mineral is a replica of Belgian Ardennes stone. The lightly brushed-hammered surface combined with fine veins and a homogeneous grain perfectly mimics natural stone. The careful balance of richness and detail and naturalness of the surface creates a modern stone effect range with discreet elegance – ideal in contemporary design settings.









Dawson Mineral



Dawson Mineral

			White	Pearl	Grey	Smoke	Tarmac
  Floor & Wall Furniture							
120x278 cm - 47 ¹ / ₄ "x109 ¹ / ₂ "	± 6 mm	Matte *	Matte *	Matte *	Matte *	Matte *	Matte *
120x240 cm - 47 ¹ / ₄ "x94 ¹ / ₂ "	± 9 mm	Matte Sensitech *	Matte Sensitech *	Matte Sensitech *	Matte Sensitech *	Matte Sensitech *	Matte Sensitech *
120x120 cm - 47 ¹ / ₄ "x47 ¹ / ₄ "	± 9 mm	Matte Sensitech	Matte Sensitech	Matte Sensitech	Matte Sensitech	Matte Sensitech	Matte Sensitech
75x150 cm - 29 ¹ / ₂ "x59"	± 9 mm	Matte Sensitech	Matte Sensitech	Matte Sensitech	Matte Sensitech	Matte Sensitech	Matte Sensitech
75x75 cm - 29 ¹ / ₂ "x29 ¹ / ₂ "	± 9 mm	Matte Sensitech	Matte Sensitech	Matte Sensitech	Matte Sensitech	Matte Sensitech	Matte Sensitech
60x120 cm - 23 ⁵ / ₈ "x47 ¹ / ₄ "	± 9 mm	Matte Sensitech	Matte Sensitech	Matte Sensitech	Matte Sensitech	Matte Sensitech	Matte Sensitech
60x60 cm - 23 ⁵ / ₈ "x23 ⁵ / ₈ "	± 9 mm	Matte Sensitech	Matte Sensitech	Matte Sensitech	Matte Sensitech	Matte Sensitech	Matte Sensitech
30x60 cm - 11 ⁵ / ₈ "x23 ⁵ / ₈ "	± 9 mm	Matte Sensitech	Matte Sensitech	Matte Sensitech	Matte Sensitech	Matte Sensitech	Matte Sensitech
  Countertops Furniture							
162x324 cm - 63 ³ / ₄ "x127 ¹ / ₂ " > Non rectified - non rettificato	± 12 mm			Hammered			
 Outdoor							
60x60 cm - 23 ⁵ / ₈ "x23 ⁵ / ₈ "	± 9 mm	Grip Sensitech	Grip Sensitech	Grip Sensitech	Grip Sensitech	Grip Sensitech	Grip Sensitech
60x120 cm - 23 ⁵ / ₈ "x47 ¹ / ₄ "	± 9 mm	Grip Sensitech	Grip Sensitech	Grip Sensitech	Grip Sensitech	Grip Sensitech	Grip Sensitech
120x240 cm - 47 ¹ / ₄ "x94 ¹ / ₂ "	± 20 mm			Outdoor Sensitech *			
120x120 cm - 47 ¹ / ₄ "x47 ¹ / ₄ "	± 20 mm	Outdoor Sensitech		Outdoor Sensitech	Outdoor Sensitech	Outdoor Sensitech	Outdoor Sensitech
60x120 cm - 23 ⁵ / ₈ "x47 ¹ / ₄ "	± 20 mm	Outdoor Sensitech		Outdoor Sensitech	Outdoor Sensitech	Outdoor Sensitech	Outdoor Sensitech
60x90 cm - 23 ⁵ / ₈ "x35 ³ / ₈ "	± 20 mm	Outdoor Sensitech		Outdoor Sensitech	Outdoor Sensitech	Outdoor Sensitech	Outdoor Sensitech
60x60 cm - 23 ⁵ / ₈ "x23 ⁵ / ₈ "	± 20 mm	Outdoor Sensitech		Outdoor Sensitech	Outdoor Sensitech	Outdoor Sensitech	Outdoor Sensitech

The colour representations shown in this data sheet are as accurate as the limitations of the printing process will allow. Due to the manufacturing process of our floor tiles there may be a small variation in the PTV value. The slip resistance values are correct at the time of testing and represent the standard production value. Inadequate cleaning and maintenance will lead to significant reduction in the slip resistance of any tiles. The pendulum test results have been displayed in line with H&S Executive guidelines whereby 0-24 represents high slip potential, 25-33 moderate slip potential & 36+ represents a low slip potential.

For further information contact: T: 0116 276 2532 – W: www.parkside.co.uk – E: info@parkside.co.uk

Strata Technical Tiles is the partner brand of Parkside Architectural Tiles



Venus Lux 60x120cm



Brick Mosaic 30x60cm



Square Mosaic
30x30cm



Domino Lux Mosaic
29.2x35cm

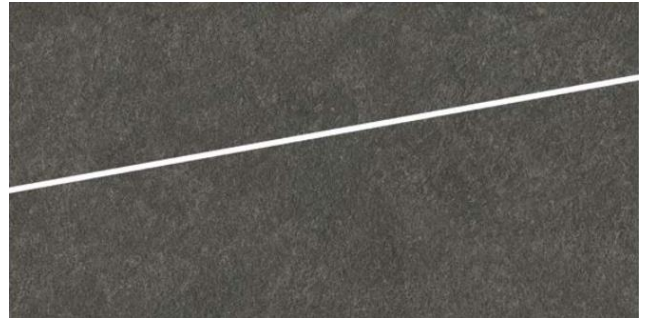

Slice A&B 20mm 60x120cm

All of these decorative tiles are available in all colours

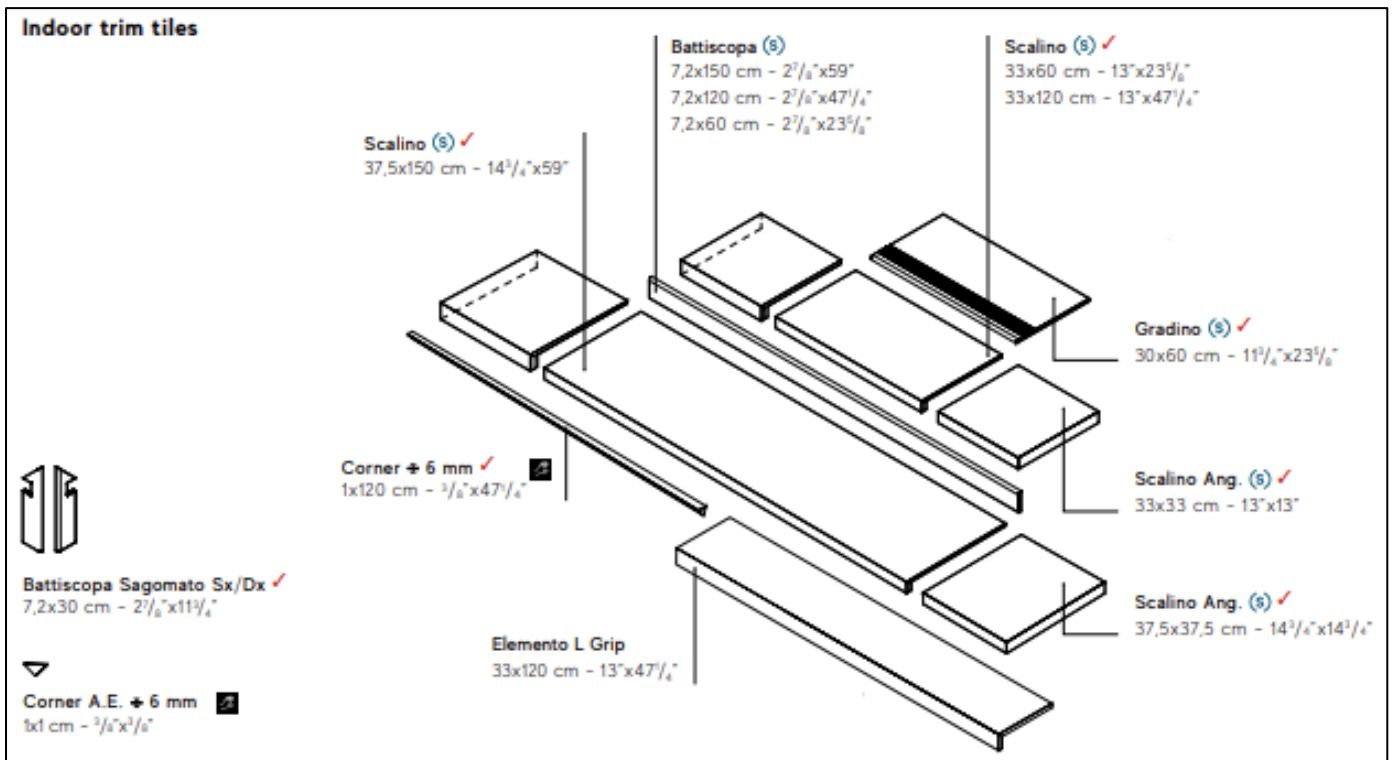

The colour representations shown in this data sheet are as accurate as the limitations of the printing process will allow. Due to the manufacturing process of our floor tiles there may be a small variation in the PTV value. The slip resistance values are correct at the time of testing and represent the standard production value. Inadequate cleaning and maintenance will lead to significant reduction in the slip resistance of any tiles. The pendulum test results have been displayed in line with H&S Executive guidelines whereby 0-24 represents high slip potential, 25-35 moderate slip potential & 36+ represents a low slip potential.

For further information contact: T: 0116 276 2532 – W: www.parkside.co.uk – E: info@parkside.co.uk

Strata Technical Tiles is the partner brand of Parkside Architectural Tiles

Dawson Mineral

Outdoor trim tiles ± 20 mm



Round SP ♦♦✓
 33x120 cm - 13"x47¹/₄"
 60x90 cm - 23⁵/₈"x35³/₈"
 30x60 cm - 11¹/₄"x23⁵/₈"



Elemento L SP ♦♦✓
 33x120 cm - 13"x47¹/₄"
 33x90 cm - 13"x35³/₈"



Bordo Piscina ♦♦✓
 30x60 cm - 11¹/₄"x23⁵/₈"



Gradino Round ♦♦✓
 30x60 cm - 11¹/₄"x23⁵/₈"



Smussato SP ♦✓
 30x60 cm - 11¹/₄"x23⁵/₈"



Alzata SP ♦✓
 20x120 cm - 7⁷/₈"x47¹/₄"
 20x90 cm - 7⁷/₈"x35³/₈"

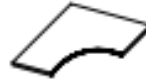

Curve SP ♦✓
 60x60 cm - 23⁵/₈"x23⁵/₈"



Griglia ♦♦✓
 15x60 cm - 5⁷/₈"x23⁵/₈"
 20x60 cm - 7⁷/₈"x23⁵/₈"

- ♦ Available in / Disponibile in White, Grey, Smoke, Tarmac
- ✓ These parts are supplied to order / I pezzi sono disponibili su ordinazione
- ♦ Right-left angular elements are available / Sono disponibili gli elementi angolari dx/sx



The colour representations shown in this data sheet are as accurate as the limitations of the printing process will allow. Due to the manufacturing process of our floor tiles there may be a small variation in the PTV value. The slip resistance values are correct at the time of testing and represent the standard production value. Inadequate cleaning and maintenance will lead to significant reduction in the slip resistance of any tiles. The pendulum test results have been displayed in line with H&S Executive guidelines whereby 0-24 represents high slip potential, 25-35 moderate slip potential & 36+ represents a low slip potential.

For further information contact: T: 0116 276 2532 – W: www.parkside.co.uk – E: info@parkside.co.uk

Strata Technical Tiles is the partner brand of Parkside Architectural Tiles

Dawson Mineral

GROUP / BLA - PORCELAIN

	Standard	Requirement	Established Values
Length and Width	ISO 10545-2	±0.6% ~ ±2mm	Conforms
Thickness	ISO 10545-2	±5% ~ ±0.5mm	Conforms
Straightness	ISO 10545-2	±0.5% ~ ±1.5mm	Conforms
Flatness	ISO 10545-2	±0.5% ~ ±2.0mm	Conforms
Rectangularity	ISO 10545-2	±0.5% ~ ±2.0mm	Conforms
Water Absorption	ISO 10545-3	$E_b \leq 0.5\%$	$E_b \leq 0.5\%$
Breaking Strength	ISO 10545-4	$\geq 1300N$	$\geq 1300N$
Modulus of Rupture	ISO 10545-4	Ave Minimum 35 N/mm ²	40 N/mm ²
Resistance to deep abrasion (unglazed tiles)	ISO 10545-6	$\leq 175mm^2$	$\leq 150 mm^3$
Thermal Shock Resistance	ISO 10545-9	Pass according to EN ISO 10545-1	Resistant
Frost Resistance	ISO 10545-12	Pass according to EN ISO 10545-1	Resistant
Resistance to household chemicals and swimming pool salts	ISO 10545-13	Min Class UB	UA
Resistance to high concentrations of alkalis and acids	ISO 10545-13	Declare Value	UHA
Resistance to low concentrations of alkalis and acids	ISO 10545-13	Declare Value	ULA
Resistance to Stain	ISO 10545-14	Declare Value	Class 5
Reaction to Fire		Class A1 A1/FL	Class A1 A1/FL

Slip Resistance Characteristics	Pendulum Dry (4S Slider 96) +36	Pendulum Wet (4S Slider 96) +36
Full Range	✓	×

Recycled Content	10 %	20%
Range Name	Dawson Mineral	Dawson Mineral 20mm

The colour representations shown in this data sheet are as accurate as the limitations of the printing process will allow. Due to the manufacturing process of our floor tiles there may be a small variation in the PTV value. The slip resistance values are correct at the time of testing and represent the standard production value. Inadequate cleaning and maintenance will lead to significant reduction in the slip resistance of any tiles. The pendulum test results have been displayed in line with H&S Executive guidelines whereby 0-24 represents high slip potential, 25-35 moderate slip potential & 36+ represents a low slip potential.

For further information contact: T: 0116 276 2532 – W: www.parkside.co.uk – E: info@parkside.co.uk

Strata Technical Tiles is the partner brand of Parkside Architectural Tiles